

Liquid Level Switches for Hazardous Areas (LLIS)

User Manual



Revision No.	Description	Date	Author Initials
01	New document created (previously PST-UM-1201-EN-02)	08/2025	WN
02	Appendices updated	12/2025	WN
03	Marking information added	02/2026	WN



Liquid Level Switches for Hazardous Areas (LLIS)

This document is the property of SST Sensing Ltd and may not be copied or otherwise reproduced, communicated to third parties, nor stored in any Data Processing System without the express written authorization of SST Sensing Ltd.

©2025 SST Sensing Ltd

Contents

1 Before using your Liquid Level Switch	4
1.1 Safety Information.....	4
1.2 Abbreviations.....	4
2 Introduction to Liquid Level Switches for Hazardous Areas (LLIS).....	5
2.1 Overview.....	5
2.2 Structure.....	6
2.3 How your LLIS senses.....	7
2.4 Applications.....	7
3 Installation.....	8
3.1 Unpack the LLIS.....	8
3.2 Mount your liquid level switch.....	9
3.3 Electrical connection.....	11
3.4 Maintenance and inspection.....	12
4 Appendices.....	13
<i>Appendix A - Technical Specifications</i>	13
<i>Appendix B - Hazardous area certification.....</i>	14
<i>Appendix C - Process connection options.....</i>	15
<i>Appendix C - Process connection options (cont.).....</i>	16
<i>Appendix D – Descriptive System Drawing.....</i>	17
<i>Appendix E – Marking Information.....</i>	18

1 Before using your Liquid Level Switch

1.1 Safety Information

Please read this manual, ensuring that you fully understand the content before attempting to install, maintain or use the Liquid Level Switch. Important safety information is highlighted throughout this document as follows:

 The **warning** symbol indicates instructions that must be followed to avoid minor, serious or even fatal injury to personnel.

 The caution symbol indicates instructions that must be followed to avoid damage to equipment (hardware and/or software) or the occurrence of a system failure.

NOTE highlights an essential operating procedure, condition, or statement.

1.2 Abbreviations

AC	Alternating Current
DC	Direct Current
°C	Degrees Celsius
°F	Degrees Fahrenheit
g	Grams
GND	Ground
kg	Kilogram
LED	Light Emitting Diode
mA	Milliampere
mW	Milliwatts
OEM	Original Equipment Manufacturer
oz	Ounces
SS	Stainless Steel
V	Volts

2 Introduction to Liquid Level Switches for Hazardous Areas (LLIS)

This manual is applicable to the SST intrinsically safe range of optical liquid level switches (LLIS) designed for use in hazardous areas where contact with hydrocarbons, fuels, diesel, flammable or explosive gases is likely.

2.1 Overview

This range of liquid level switches is ATEX/UKEX/IECEx certified as intrinsically safe when used to sense levels of most liquids in potentially hazardous locations.

This instrument is designed as EPL Ga which is normally suitable for use in hazardous areas of Zones 0, 1, and 2. It is designed for Equipment Groups IIA, IIB, and IIC with a temperature classification of T4 as defined by EN/IEC standards 60079-0, and 60079-11 (latest versions).

It is designed for the ATEX Equipment Directive 2014/34/EU for equipment-group II category 1.

Using infrared technology and the principle of total internal reflection, these optical liquid level switches detect the presence or absence of most liquids with an almost instantaneous response time.

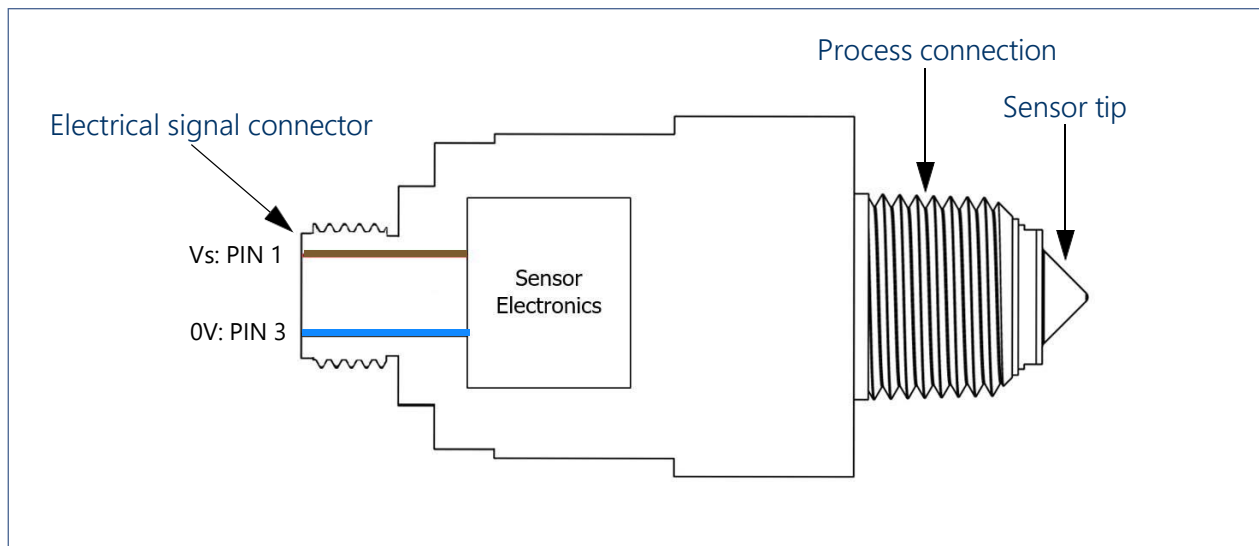

Figure 1. Internal structure

2.2 Structure

The intrinsically safe LLIS is encased in a sealed, stainless-steel housing, with a user-selectable process connection thread at the sensor end, and an M12 electrical signal connector at the opposite end, see Figure 2.

See *Appendix C - Process connection options*.

The stainless-steel housing and a choice of sensing tip materials ensure our LLIS for hazardous areas is robust and resistant to chemical attack.

NOTE: There are no user replaceable parts.

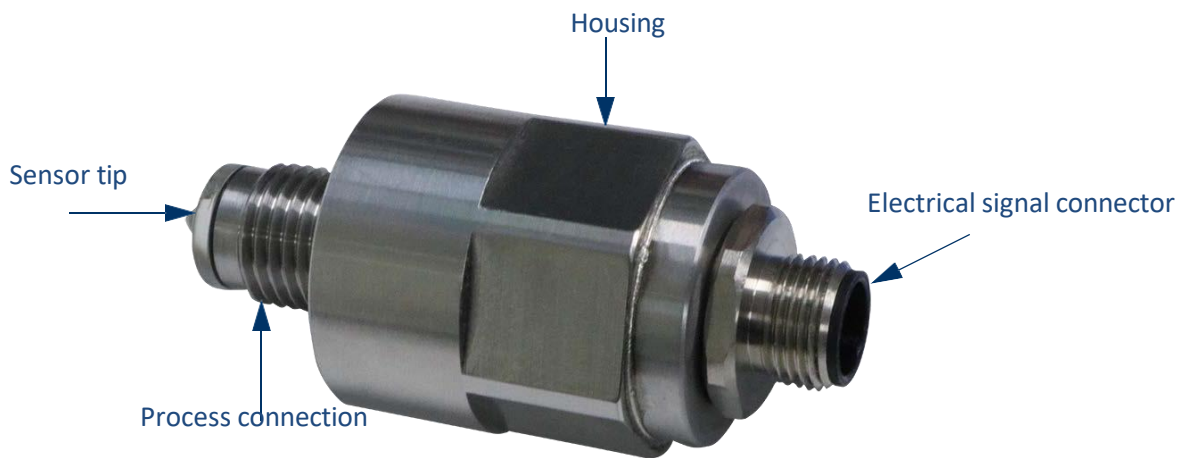

Figure 2. External components

2.3 How your LLIS senses

An optical liquid level sensor uses an infrared LED and phototransistor precisely positioned at the base of the sensor's tip. When the sensor tip is in air, infrared light reflects internally round the tip to the phototransistor, providing optical coupling between the components.

When the sensor's tip is immersed in liquid, the infrared light escapes from it, causing a change in the amount of light at the phototransistor. This changes the output state.

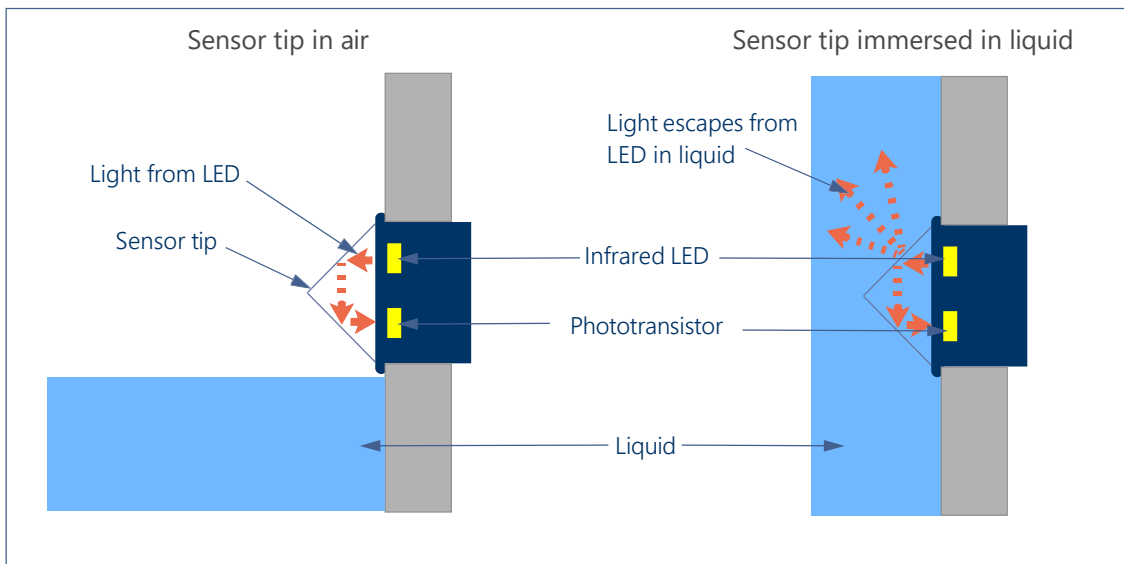

Figure 3. Output state differences

2.4 Applications

Typically, our intrinsically safe liquid level switches for hazardous areas can be used in the following applications:

- Petrochemicals
- Leak detection
- Heavy-duty automotive
- Hydraulic reservoirs
- Hydrogen generation
- Tank and container level control
- Downstream analyzer protection.

3 Installation

NOTE: Installation, operation and maintenance of this equipment should be carried out only by appropriately trained and suitably qualified technicians in accordance with the instructions in this user manual, and any applicable standards/certificates associated with the country, industry and application.

! Failure to correctly adhere to these instructions may result in serious or even fatal injury. In this regard, the manufacturer will not be held liable.

NOTE: No modification should be made to the instrument without reference to the manufacturer, as unauthorized modification to an approved apparatus will invalidate the certificate/approval/warranty.

! Do not operate damaged equipment. If faults cannot be rectified, the equipment must be taken out of service and secured against unintentional commissioning.

Before installing your liquid level switch, ensure that its specifications are suitable for the process where it will be installed. Ensure the details on the label comply with the Hazardous Area specified.

! Protect the device from accidental shock or vibration as this may damage the sensor.

3.1 Unpack the LLIS

Your Liquid level switch may not be supplied with cables or cable connectors. Please provide a suitable cable fitted with an M12 connector.



Figure 4. Contents of LLIS package

3.2 Mount your liquid level switch

NOTE: External heating or cooling via mounting must not cause the device to exceed the stated ambient temperature range. *See Appendix A - Technical Specifications*

Your optical liquid level switch must be mounted with the sensor tip pointing sideways or upwards for proper use. It must not be mounted with the sensor tip facing downwards as liquid droplets forming there could produce false readings.

Optical liquid level switch performance can be affected by the location of reflective surfaces in front of the sensor tip.

- If the LLIS is mounted towards the top of a vessel it ensures against overfilling.
- Equipment mounted further inside a vessel will detect a maximum or minimum limit level.
- A liquid level switch installed at the bottom of a vessel or on an out-feed pipe, can protect against dry-running.

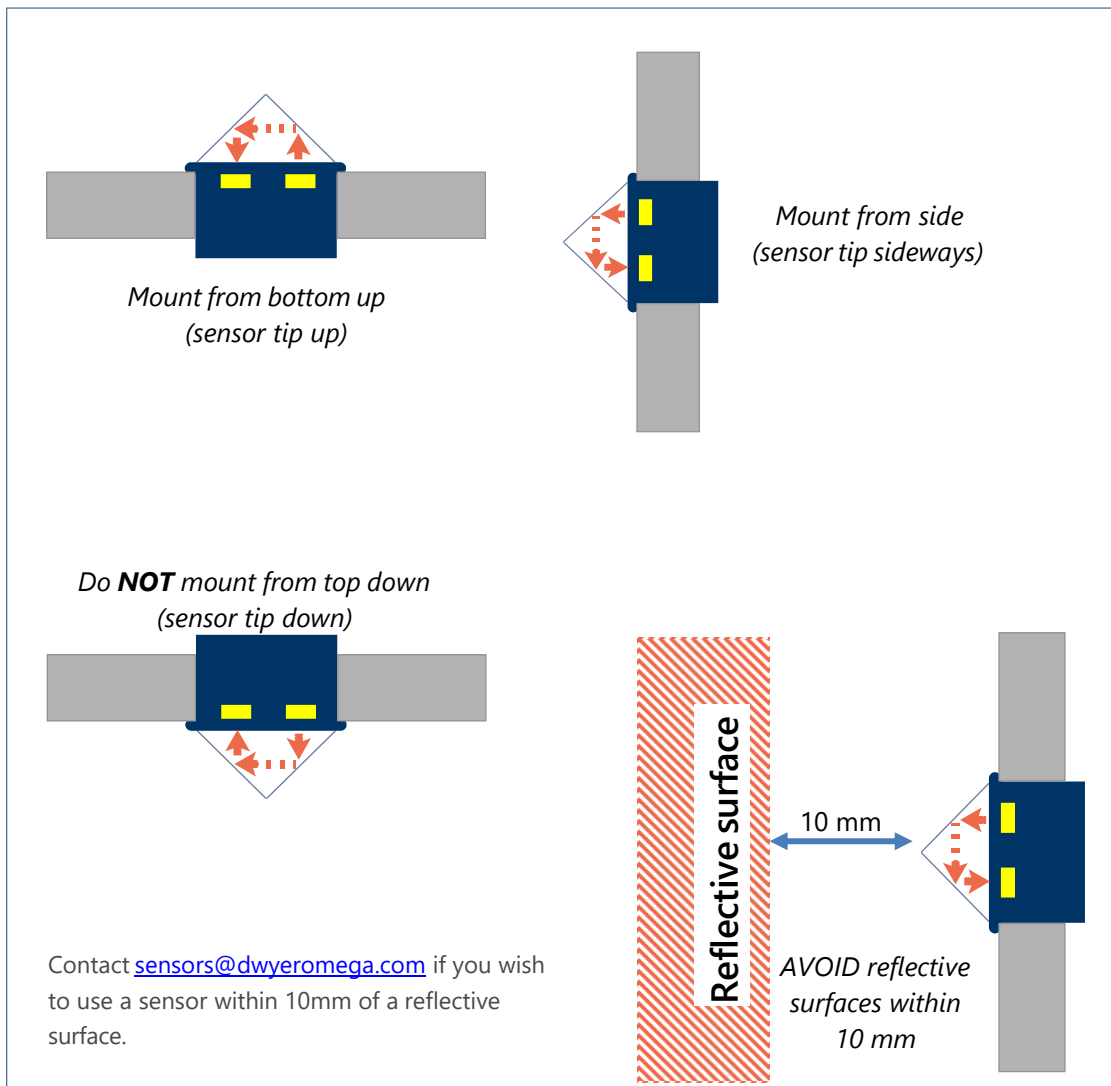

Figure 5. LLIS mounting and orientation

Before mounting your LLIS, ensure that its specifications are suitable for the process, vessel or pipeline where it will be installed. **See Appendix A - Technical Specifications and Appendix C - Process connection options for further guidance.**

1. Ensure the LLIS is suitably sealed to the vessel, which should be fitted with an appropriate sample connection/thread.
2. Mount your LLIS to your process by rotating the process connection clockwise into your vessel at the sample connection. Ensure the sensor tip is facing either upwards or sideways dependent on your application, as shown in Figure 5 on the previous page.
3. Continue to **Section 2.3 Electrical connection** on the next page.

3.3 Electrical connection



All wiring **must** be in accordance with the National Electrical Code and any local codes, ordinances, and regulations.

Disconnect and lock out power before connecting the equipment to the power supply.

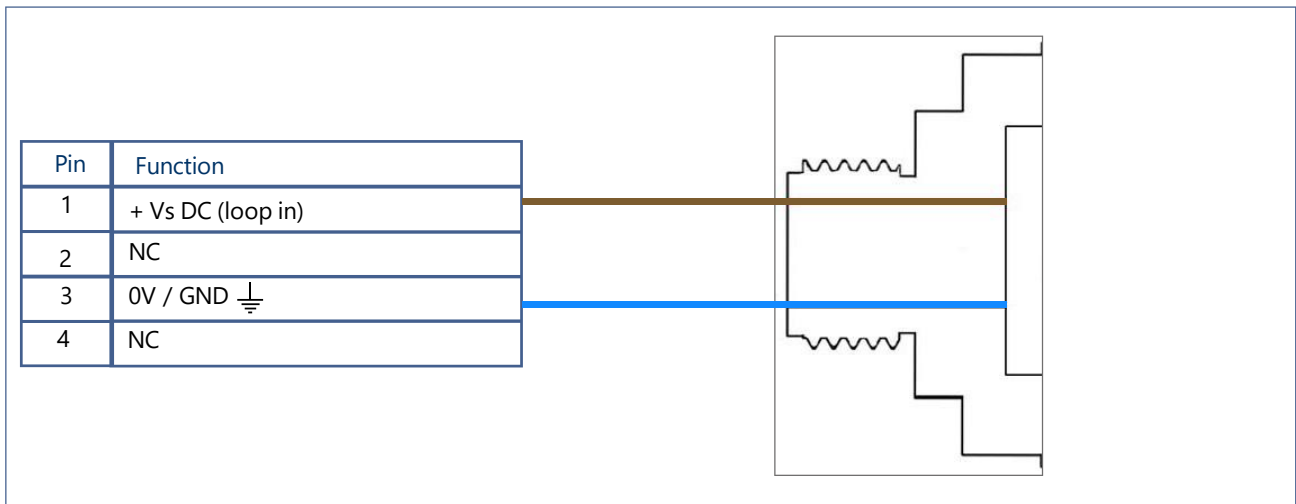

Figure 6. Pin connections



Do not install the device suspended from the cable. Avoid exerting excessive tensile force on the cable.

1. Connect only to an appropriately selected intrinsically safe circuit, for example the output of a Zener Barrier or other suitable associated apparatus.
2. After ensuring power has been disconnected and locked out, align the pins on the electrical signal connector with the M12 mating connector on the cable. The cable can then be gently pushed into place.
3. Rotate the fastener clockwise until finger tight. The sensor is now connected to the electrical supply.
4. If using a cable with more than two cores, you must ensure that any spare cores are terminated correctly at the connected equipment end by either:
 - (a) insulating by the use of suitable terminations or insulation, for example with heat shrink tubing over the wire end; or
 - (b) by connected to the earth point used to earth the connected circuit (usually at the barrier).
5. It is now safe to reconnect power.

3.4 Maintenance and inspection

1. Frequent inspection should be made. A schedule for maintenance checks should be determined by the environment and frequency of use but should be regular enough to ensure the equipment continues to operate in the designed manner.
2. External parts of the instrument enclosure should be periodically cleaned to ensure dust deposits are not allowed to accumulate.

All statements, technical information and recommendations contained herein are based on information and tests we believed to be reliable, the accuracy or completeness thereof are not guaranteed and since conditions of use are outside our control, the purchaser should determine the suitability of the product for its intended use and assumes all risk and liability whatsoever in connection herewith.

HEALTH AND SAFETY AT WORK ACT

In the UK all equipment must be installed and disposed of (as required) within the legislative requirements of the Health & Safety at Work Act 1974. All other international Health & Safety regulations must be complied with.

4 Appendices

Appendix A - Technical Specifications

Process connections					
Thread	3/8" G	3/8" NPT	1/2" NPT	1/2" G	M14 x 1.5
Pressure	32 bar (464 psi) maximum				
Sensor tip	Polysulfone / Trogamid / Grilamid				
Seal O-Ring	Viton / Nitrile				
Housing material	316 Stainless Steel				
Electrical input /output					
Power supply	+5 V DC...12 V DC (+8.2 V nominal)				
Supply current	Liquid detected: >3 mA; Air detected: <1 mA				
Output type	NAMUR				
Safety parameters	Ui = 12V Ii = 130 mA Pi = 85 mW Ci = 1.08µF				
Operating temperatures	-30 °C...+80 °C (-22 °F...+176 °F)				
Storage temperatures	-25 °C...+70 °C (-13°F...+158°F)				
Interface*	M12, 4-pin, A-coded connector				
Mechanical					
Weight	<100 g (<3.5 oz)				

Appendix B - Hazardous area certification

Area	Certification details	Standards
<p>Europe</p>	<p>IECEX / ATEX / UKEX ATEX / UKEX: II 1 G Ex ia IIC T4 Ga (Ta = -30 °C...+80 °C) IECEx: Ex ia IIC T4 Ga (Ta = -30 °C...+80 °C)</p>	<p>EN 60079-0:2018 EN 60079-11:2012 IEC 60079-0:2017 IEC 60079-11:2011</p>

Appendix C - Process connection options

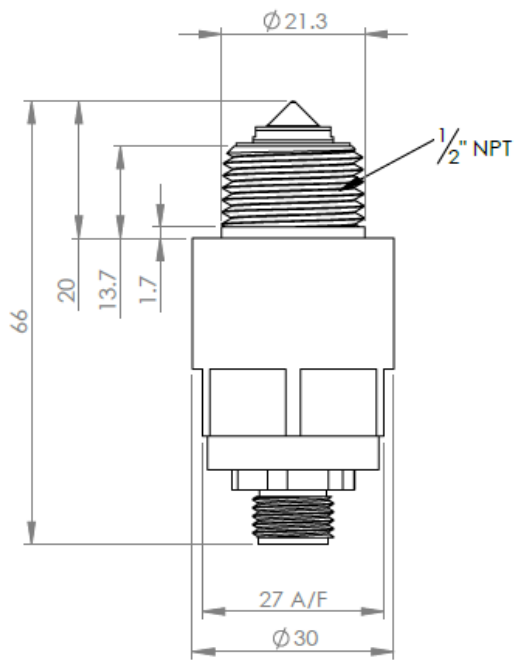
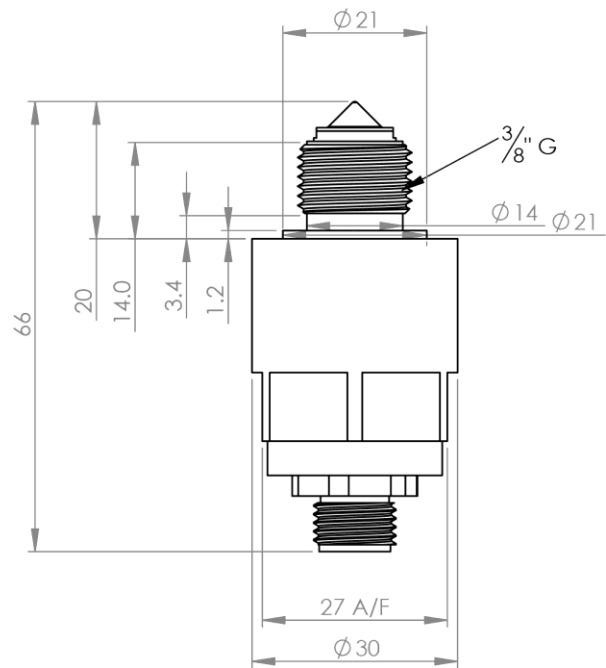
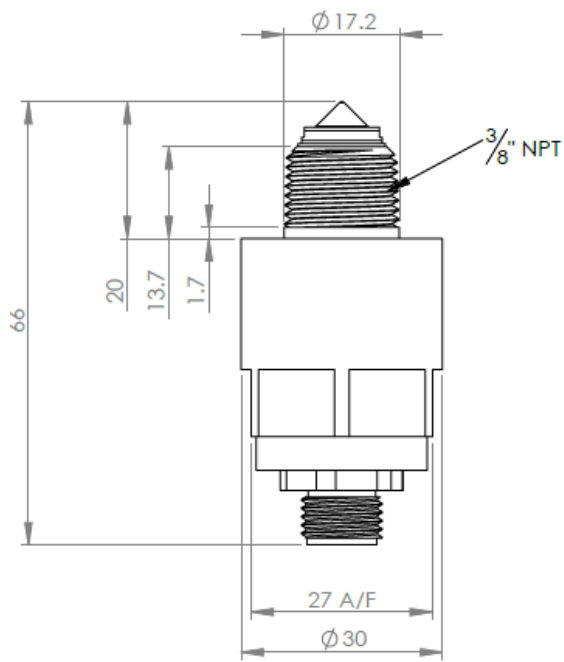

Appendix C - Process connection options (cont.)

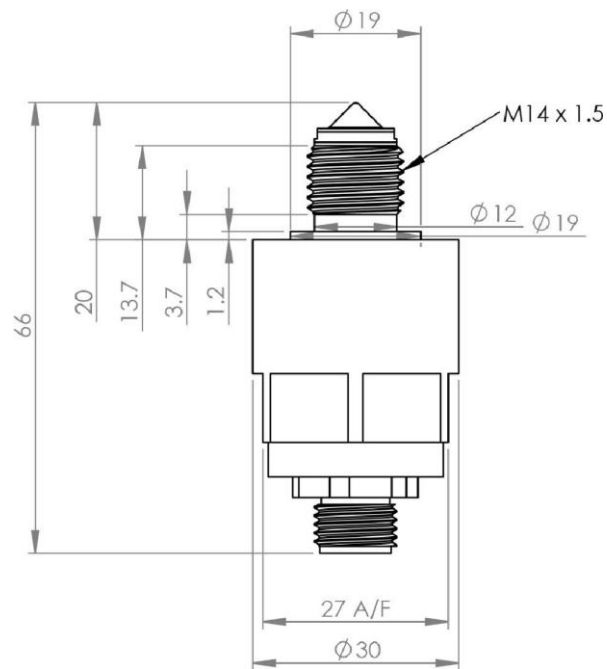
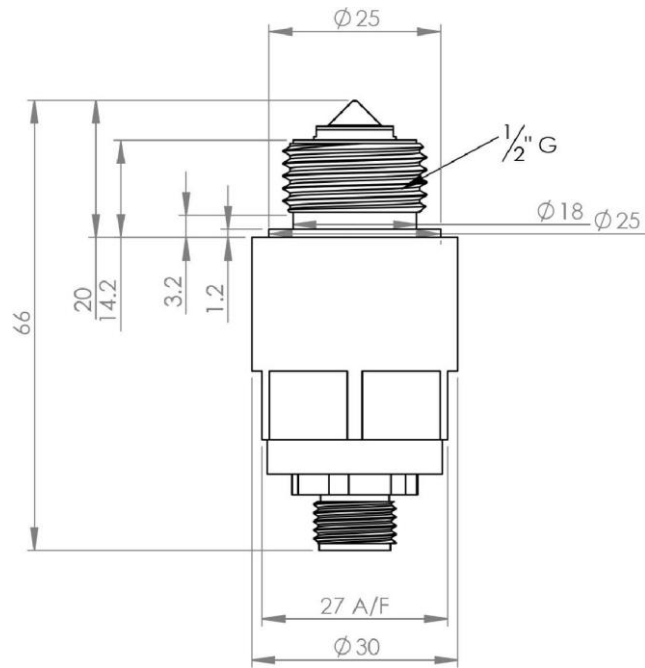

Appendix D – Descriptive System Drawing

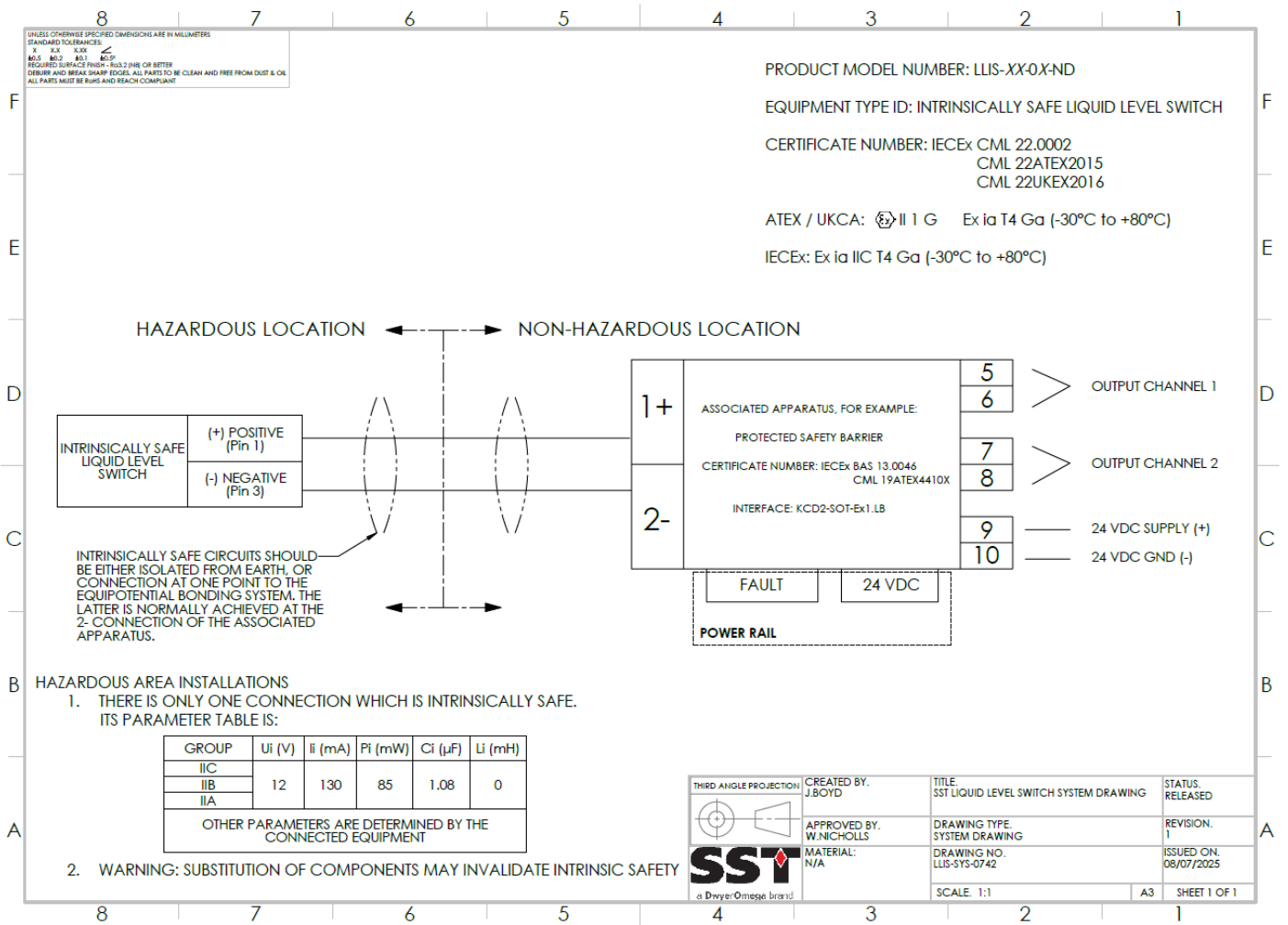

Appendix E – Marking Information

All marking to be legible and indelible.

Marking applied as a laser etching to the side of the enclosure.

Product ID : **LLIS-XX-XX-ND**

Name of Manufacturer : **SST Sensing Ltd**

Manufacturer Address: **ML5 4NS, UK**

Serial Number: **YY-ID NUMBER**

ATEX Marking: **Ⓔ II 1 G**

IECEX Marking: **Ex ia IIC T4 Ga**

ATEX certificate number: **CML22ATEX2015**

UKEX certificate number: **CML22UKEX2016**

IECEX certificate number: **IECEX CML22.0002**

CE mark with Notified Body number: **CE_{XXXX}**

CE and UKCA marks to appear as shown
XXXX to be replaced with ExNB number of assessor for EU QAN
YYYY to be replaced with ExAB(UK) number of assessor for UK QAN

UKCA mark with Approved Body number: **UK_{CA} YYYY**

Ambient Temperature Range: **Ta -30°C to +80°C**

Entity Parameters: **Ui = 12V, Pi = 85mW, Ii=130mA, Ci=1.08µF**



 **DWYEROMEGA™**
Improving the world, one measurement at a time™

 **Analytical Industries Inc**  **DYNAMANT**  **SST**  **SEN SORE**
INFRARED GAS SENSORS

SST Sensing Ltd, 5 Hagmill Crescent, Coatbridge, ML5 4NS United Kingdom, Tel: +44 1236 459020
www.sstsensing.com, e-mail: sensors@dwyeromega.com